

VENTILAZIONE
CON GRIGLIA

TRIPLO
VETRO
ANTI UV

SISTEMA
ANTIVIBRAZIONE

CLASSE
ENERGETICA - G

NERA
SQUADRATA

CANTINA 150 BOTTIGLIE 1 TEMPERATURA NNW180-150S-BFG

Installazione: Integrale | Libero Posizionamento

Capacità Ca.	Capacità ca. 150 bottiglie (75 Cl. Tipo Bordelesi)
Tipo Di Comando	Computer evoluto, Soft Touch, Display LCD
N° Zone Temperatura	Singola Temperatura
Temp. Zona	Regolabile da 2 20°C
N° Ripiani Interni	8 Ripiani scorrevoli
Tipologia Ripiani	3 Ripiani In Legno da conservazione 2 Ripiani in legno da Mescita 3 Ripiano fissi in metallo da servizio
Illuminazione Interna	Luce LED 3 colori Doppia emissione orizzontale e verticale
Filtro	Filtro ai carboni attivi
Riscaldatore	Mono Riscaldatore Interno
Finitura Porta	Nera Full Glass
Isolamento Porta	Triplo Vetro Basso Emissivo
Maniglia	Nera Squadrata
Sicurezza	Serratura con chiave
Griglia	Frontale Fissa
Compressore	Inverter 220-240 V; 50Hz - 60Hz; Gas R600a
Classe Energetica	G Climatica N-ST
Consumo Kwh/Anno	155 KWh/anno
Silenziosità	38dB
Reversibilità Porta	Reversibile
Misure (HxLxp) Cm	Prodotto 180x59,5x69,5 Imballo 186,6x64,5x77
Peso Prodotto	Peso Netto Lordo: 101 119 kg
Codice Ean	0666186409886



Ripiano fisso in metallo da Servizio



Ripiano in Legno da Mescita



Ripiano in Legno da conservazione

NNW180-150S-BFG

Misure:

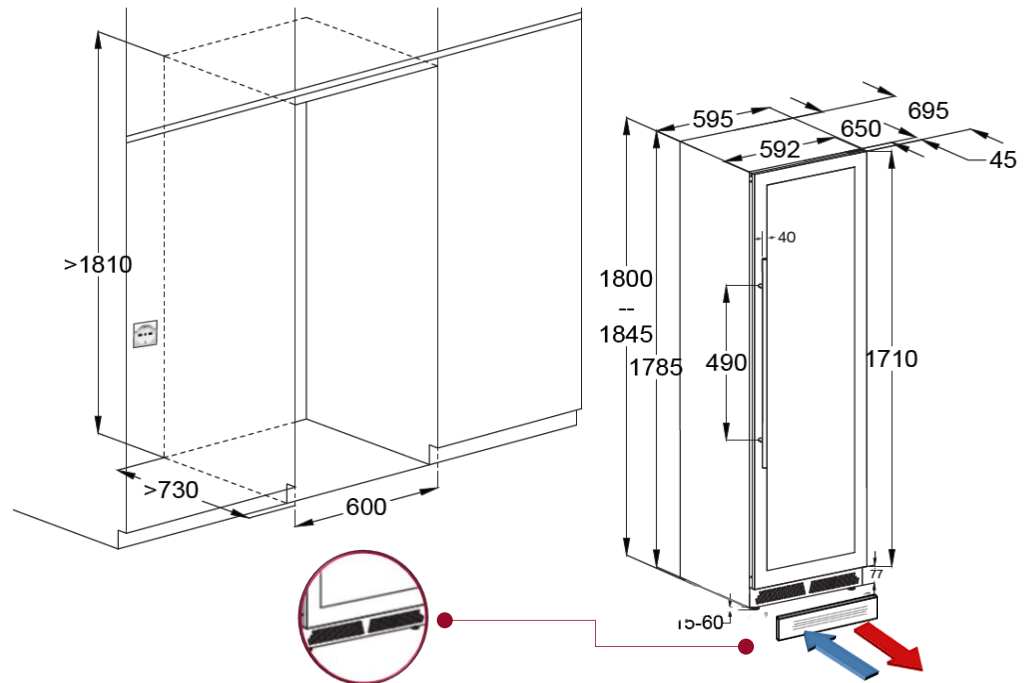

● N° DI BOTTIGLIE:

La capacità massima è espressa in N° bottiglie di tipo "Bordolese Standard". Il numero di bottiglie indicato sul catalogo prende come riferimento la bordolese classica da 750 ml (misure H 30mm e Ø 70 mm.) **Ogni altra tipologia di bottiglia modifica la capienza.**

Tutti i ripiani in legno sono estraibili e removibili in modo da ottenere uno spazio più ampio per contenere eventuali bottiglie grandi come le magnum o bottiglie con forme non convenzionali.

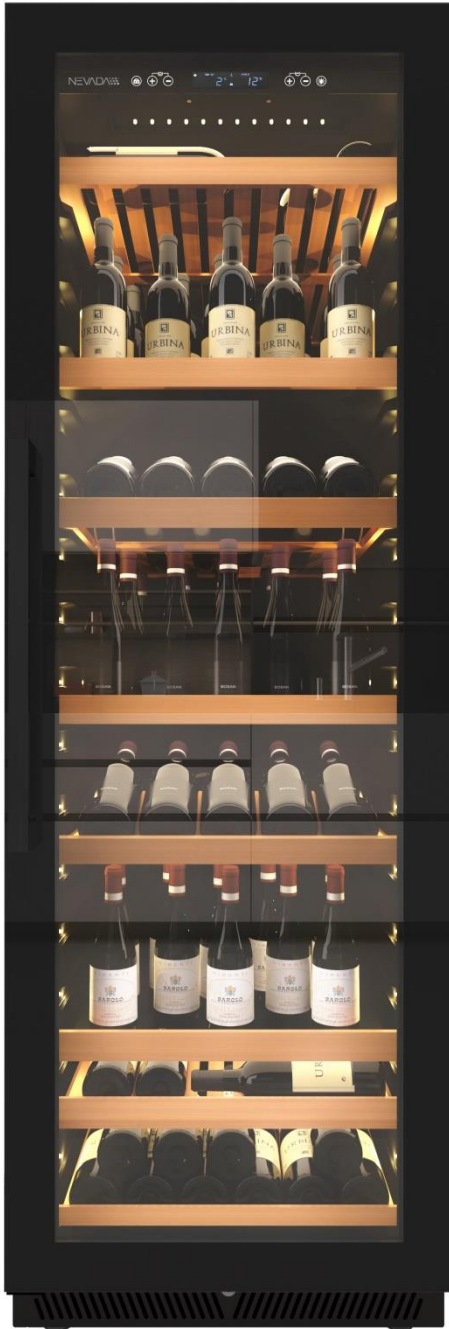

VENTILATION WITH GRID

TRIPLE ANTI-UV GLASS

ANTI-VIBRATION SYSTEM

ENERGY CLASS - G

BLACK SQUARE

WINE CELLAR 150 BOTTLES 1 TEMPERATURE NNW180-150S-BFG

Installation: Full | Free Positioning

Capacity Approx.	Capacity approx. 150 bottles (75 Cl. Bordeaux type)
Control Type	Advanced computer, Soft Touch, LCD display
No. Temperature Zones	Single Temperature
Temp. Zone	Adjustable from 2 20°C
No. Internal Shelves	8 sliding shelves
Type of Shelves	3 Wooden shelves for storage 2 Wooden shelves for serving 3 Fixed metal shelves for service
Internal Lighting	3-color LED light Horizontal and vertical double emission
Filter	Activated carbon filter
Heater	Single Internal Heater
Door Finish	Black Full Glass
Door Insulation	Triple Low Emissivity Glass
Handle	Black Square
Safety	Lock with key
Grid	Fixed Front
Compressor	Inverter 220-240 V; 50Hz - 60Hz; Gas R600a
Energy Class	G Climatic N-ST
Consumption Kwh/Year	155 KWh/year
Silent	38dB
Door Reversibility	Reversible
Dimensions (HxWxD) Cm	Product 180x59.5x69.5 Packaging 186.6x64.5x77
Product Weight	Net Gross Weight: 101 119 kg
Ean Code	0666186409886



Fixed metal shelf for service



Wooden Serving Shelf



Wooden Storage Shelf

NNW180-150S-BFG
Measures:

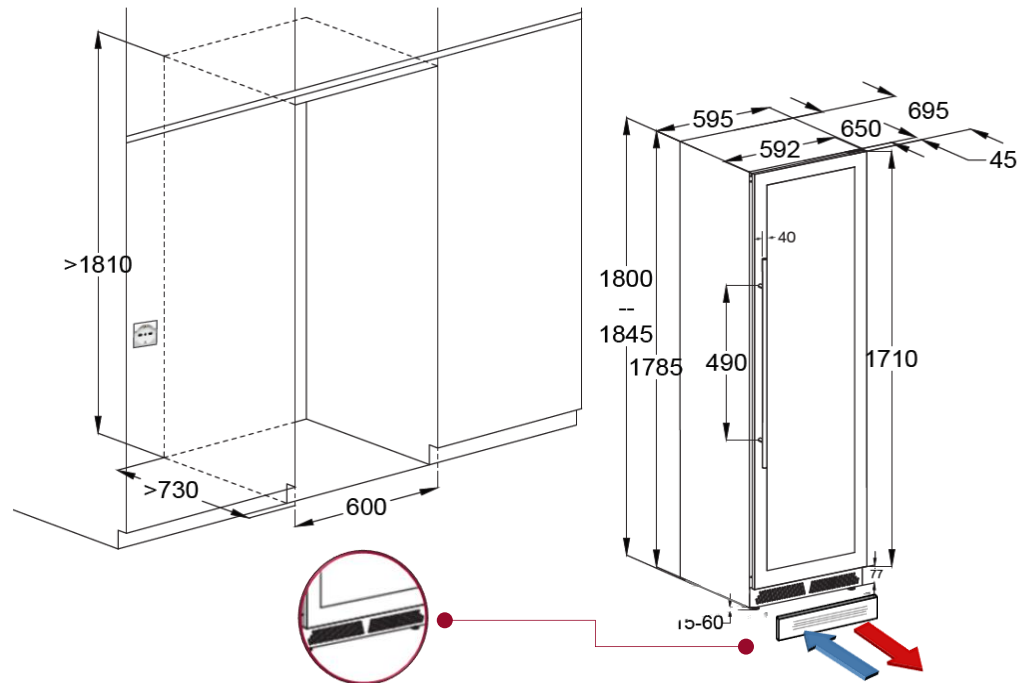

● NUMBER OF BOTTLES:

The maximum capacity is expressed in N° bottles of the "Bordolese Standard" type. The number of bottles indicated in the catalogue takes as a reference the classic 750 ml Bordeaux bottle (measurements H 30mm and Ø 70 mm). **Every other type of bottle modifies the capacity.**

All the wooden shelves are extractable and removable in order to obtain a larger space to contain any large bottles such as magnums or bottles with unconventional shapes.

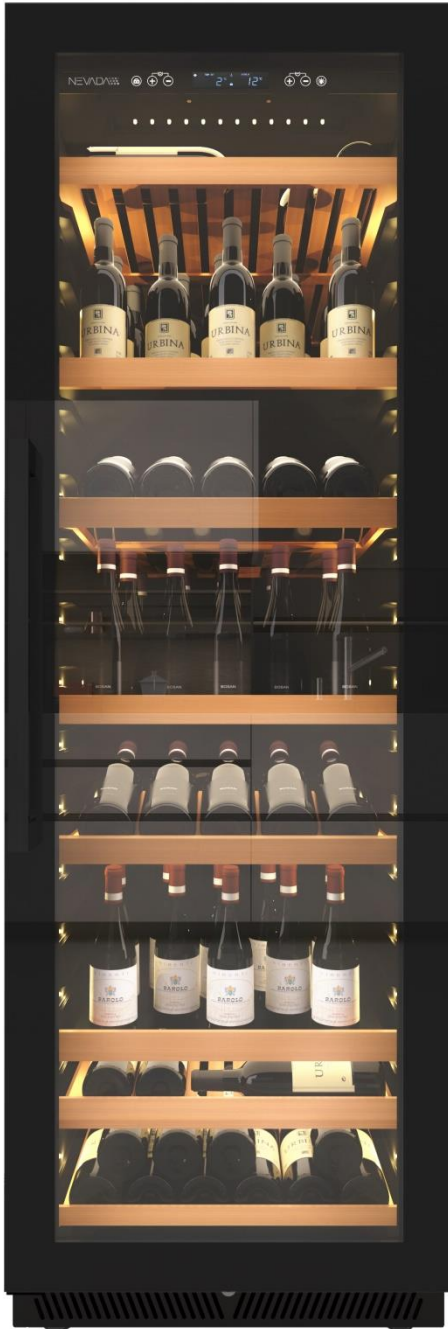

BELÜFTUNG
MIT GITTER

DREIFACHES
ANTI-UV-GLAS

ANTI-VIBRATIONSSYSTEM

ENERGIEKLASSE - G

QUADRATISCH SCHWARZ

DE

WEINKELLER 150 FLASCHEN 1 TEMPERATUR NNW180-150S-BFG

Installation: Integral | Freie Positionierung

Kapazität ca.	Fassungsvermögen ca. 150 Flaschen (75 cl. Typ Bordeaux)
Befehlstyp	Fortschrittlicher Computer, Soft Touch, LCD-Display
Nr. Temperaturzonen	Einzelne Temperatur
Zonentemperatur	Einstellbar von 2 20°C
Nr. Innenregale	8 ausziehbare Regale
Art der Regale	3 Aufbewahrungsregale aus Holz 2 Servierregale aus Holz 3 feste Serviceregale aus Metall
Innenbeleuchtung	3-farbiges LED-Licht Doppelte horizontale und vertikale Emission
Filter	Aktivkohlefilter
Heizung	Mono-Innenheizung
Türabschluss	Schwarzes Vollglas
Türisolierung	Dreifaches Low-E-Glas
Handhaben	Schwarz im Quadrat
Sicherheit	Mit Schlüssel verriegeln
Grill	Feste Vorderseite
Kompressor	Wechselrichter 220-240V; 50Hz - 60Hz; R600a-Gas
Energieklasse	G Klima N-ST
Verbrauch kWh/Jahr	155 kWh/Jahr
Schweigen	38 dB
Reversibilitätstür	Reversibel
Maße (HxBxT) cm	Produkt 180x59,5x69,5 Verpackung 186,6x64,5x77
Produktgewicht	Nettogewicht Brutto: 101 119kg
Ean-Code	0666186409886



Festes Servierregal aus Metall



Servierregal aus Holz



Aufbewahrungsregal aus Holz

NNW180-150S-BFG
Maßnahmen:

DE

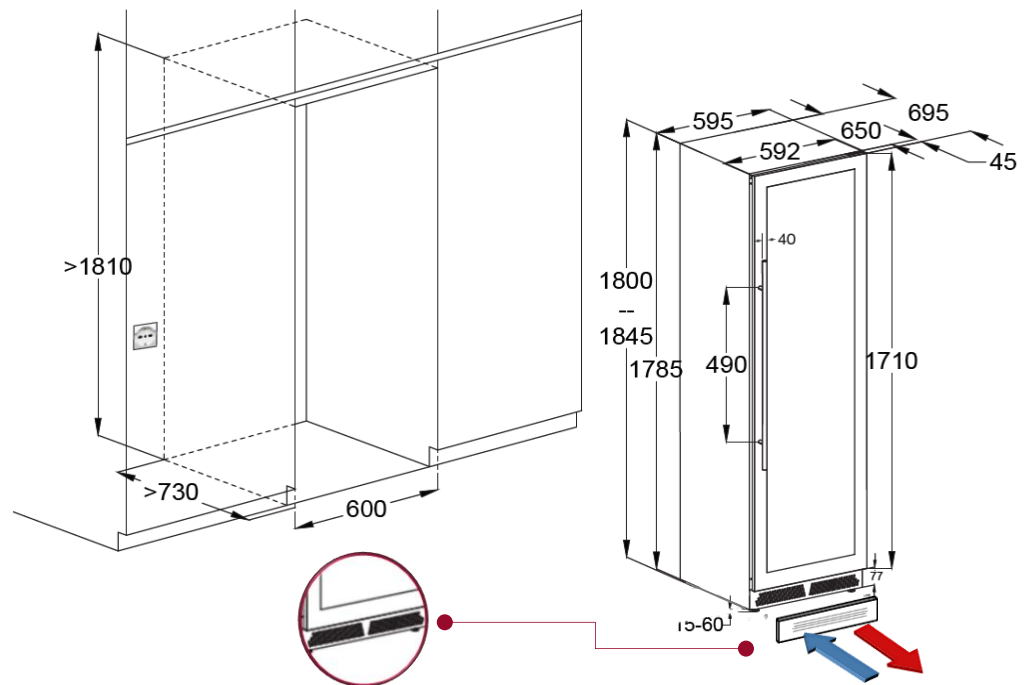

● ANZAHL DER FLASCHEN:

Die maximale Kapazität wird in der Anzahl der Flaschen des Typs "Bordolese Standard" ausgedrückt. Die im Katalog angegebene Flaschenanzahl bezieht sich auf die klassische 750-ml-Bordeauxflasche (Maße H 30 mm und Ø 70 mm). **Jeder andere Flaschentyp ändert das Fassungsvermögen.**

Alle Holzregale sind ausziehbar und abnehmbar, um mehr Platz für große Flaschen wie Magnumflaschen oder Flaschen mit unkonventionellen Formen zu schaffen.

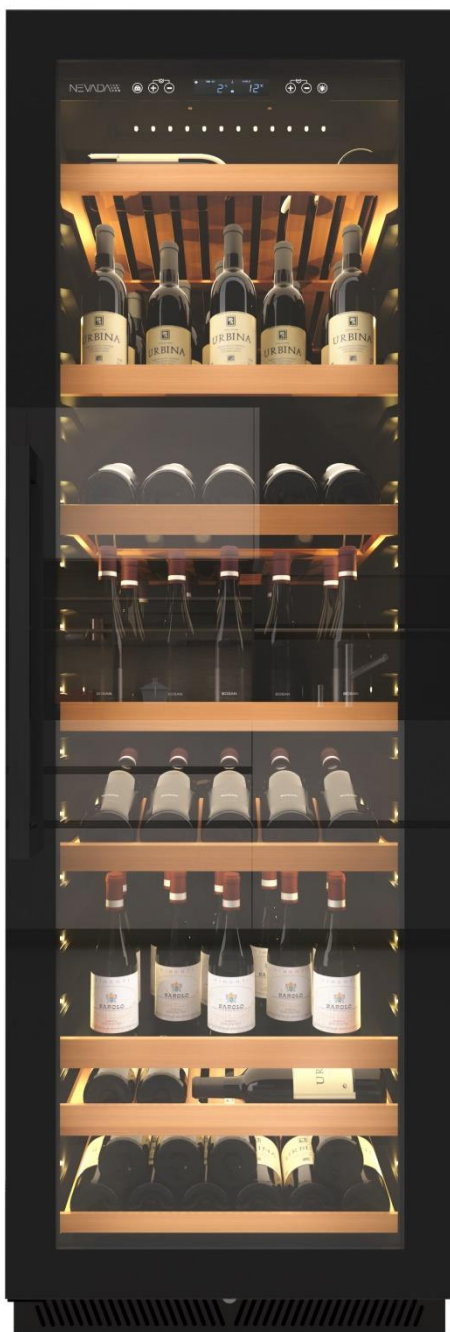

VENTILATION
AVEC GRILLE

TRIPLE
VERRE
ANTI UV

SYSTÈME
ANTI-
VIBRATIO
N

CLASSE
ÉNERGÉTI
QUE - G

CARRÉ
NOIR

FR

CAVE À VIN 150 BOUTEILLES 1 TEMPÉRATURE NNW180-150S-BFG

Installation: Intégrale | Positionnement gratuit

Capacité env.	Capacité env. 150 bouteilles (75 cl. type Bordeaux)
Type de commande	Ordinateur avancé, Soft Touch, écran LCD
N° Zones de Température	Température unique
Température de zone	Réglable de 2 20°C
N° Etagères Internes	8 étagères coulissantes
Type d'étagères	3 étagères de rangement en bois 2 étagères de service en bois 3 tablettes de service fixes en métal
Éclairage interne	Lumière LED 3 couleurs Double émission horizontale et verticale
Filtre	Filtre à charbon actif
Chauffage	Chauffage interne mono
Finition de la porte	Verre plein noir
Isolation des portes	Verre triple à faible émissivité
Poignée	Carré noir
Sécurité	Serrure avec clé
Gril	Façade fixe
Compresseur	Onduleur 220-240V ; 50 Hz - 60 Hz ; Gaz R600a
Classe énergétique	G Climat N-ST
Consommation Kwh/An	155 KWh/an
Silence	38dB
Porte Réversibilité	Réversible
Dimensions (HxLxP) Cm	Produit 180x59,5x69,5 Emballage 186,6x64,5x77
Poids du produit	Poids net Brut : 101 119 kg
Code EAN	0666186409886



Tablette de service fixe en métal



Etagère de service en bois



Etagère de rangement en bois

NNW180-150S-BFG

Mesures:

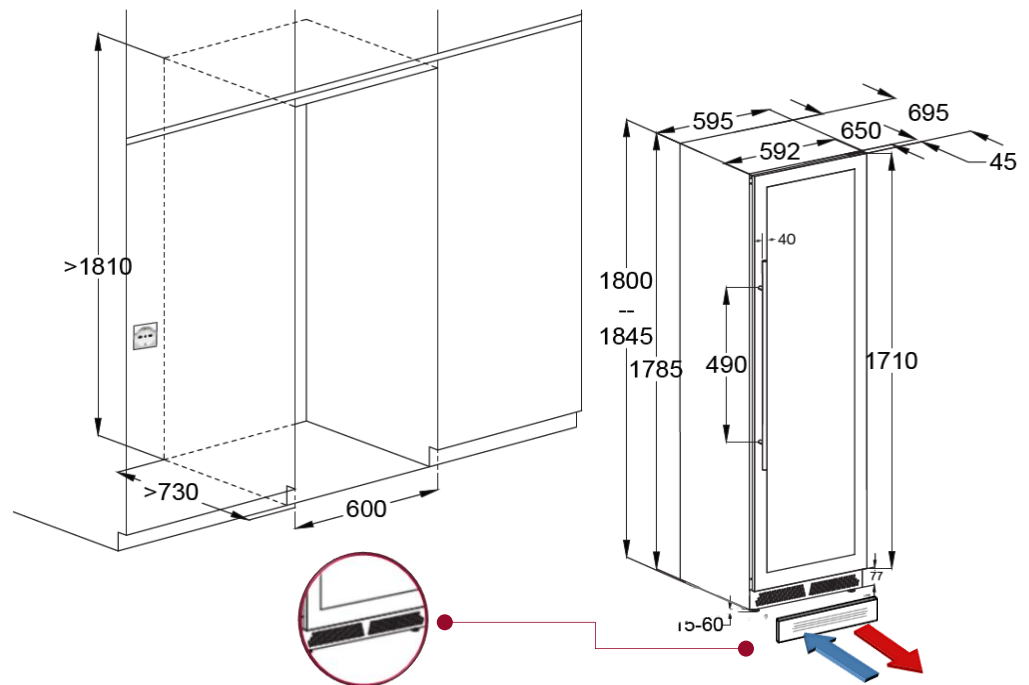

FR

● N° DE BOUTEILLES :

La capacité maximale est exprimée en nombre de bouteilles de type "Bordolese Standard". Le nombre de bouteilles indiqué dans le catalogue prend comme référence la bouteille bordelaise classique de 750 ml (mesures H 30mm et Ø 70 mm.) **Tout autre type de bouteille modifie la contenance.**

Toutes les étagères en bois sont extractibles et amovibles afin d'obtenir un plus grand espace pour accueillir d'éventuelles grandes bouteilles comme des magnums ou des bouteilles aux formes non conventionnelles.